

WARRANTY & SERVICE

We guarantee the unit to be free from defects in material or workmanship for a period of one (1) year from the date of purchase.

Operating this unit with an adapter other than the one supplied or any attempts made to service or modify the unit, will VOID THE WARRANTY.

For your convenience, please record the complete model number and the date of purchase below, and attach your receipt as proof of purchase.

Attach your purchase receipt here

Serial No.: _____

Date of Purchase: _____

Name and address of Purchaser: _____

Telephone: _____



InvisiPure Wave Cool Mist Ultrasonic Humidifier



Model:IP-2524

READ AND SAVE THESE IMPORTANT INSTRUCTIONS

WHEN USING ELECTRICAL APPLIANCES, BASIC SAFETY PRECAUTIONS SHOULD ALWAYS BE FOLLOWED TO REDUCE THE RISK OF FIRE, ELECTRIC SHOCK, AND INJURY TO PERSONS, INCLUDING THE FOLLOWING:

1. Check the household voltage to ensure it matches the unit's rated specification before operating.
2. Children should be supervised to ensure that they do not play with the appliance.
3. DO NOT refill the unit from the mist outlet directly, or it will damage the unit.
4. DO NOT allow children to play with any product packaging, such as plastic bags.
5. To avoid fire hazards, NEVER put the cord under rugs, near heat registers, radiators, stoves, or heaters.
6. DO NOT place humidifier near heat sources such as stoves, radiators, and heaters. Do locate your humidifier on an inside wall near an electrical outlet. The humidifier should be at least 4 inches away from the wall for best results.
7. DO NOT attempt to refill humidifier without unplugging the unit from its electrical outlet first.
8. DO NOT operate any appliance with a damaged cord or plug, after the appliance malfunctions, or if it has been dropped or damaged in any manner. Return appliance to manufacturer for examination, electrical or mechanical adjustment, or repair.
9. Always place humidifier on a firm, flat, level surface at least 2 feet away from the floor.
10. DO NOT allow the moisture outlet to directly face the wall.
11. NEVER tilt, move, or attempt to empty unit while it is operating.
12. Shut off and unplug before removing the water tank and moving the unit.
13. DO NOT attempt to repair or adjust any electrical or mechanical functions on this unit. Doing so will void your warranty. The inside of the unit contains no user serviceable parts. All servicing should be performed by qualified personnel only.
14. NEVER use detergents, gasoline, glass cleaner, furniture polish, and paint thinner, or other household solvents to clean any part of the humidifier.
15. Do NOT pour water in any openings other than the water tank.
16. Excessive humidity in a room can cause water condensation on windows and furniture. If this happens, turn the humidifier OFF.
17. Never place housing under water flow or immerse in liquid.
18. DO NOT use essential oils, hot water, and other additives. For best results, use filtered or distilled water only.
19. DO NOT operate without tank or if leaking occurs.
20. Clean and dry unit after each use. Always plug and unplug the unit with dry hands to avoid electric shock.

TROUBLESHOOTING

If your humidifier is not working correctly please check the following causes:

PROBLEM	PROBABLE CAUSE	SOLUTION
Humidifier does not operate.	Power cable not plugged in.	Plug in power cable.
The power light is on, but there is no mist.	No water in water tank.	Fill tank with water.
The water mist produces an unpleasant smell.	Dirty water or the water was left in the water tank for too long.	Open the water tank and leave it for 12 hours in a shady and cool place.
		Clean the water tank and change the water.
The power light is on, but the humidifier doesn't work	Too much water in the basin.	Turn off the unit and remove water from basin. Check if O-ring seal in the water cap is seated properly. Check for leaks before use.
The mist output volume is low	The transducer is dirty.	Clean transducer with a soft-bristle brush.
	Water is too dirty or water was kept too long in the tank	Clean water tank and change the water
Abnormal noise	Resonance caused when water level is too low.	Fill the water tank.
	Unit is on an unstable surface.	Move the unit to a flat stable surface.
Very tight tank cap	Cap Overtightened.	Add liquid soap to O-ring on the water cap to ease opening for future use.
Water leaking	Water tank gasket not seated properly or water tank/basin has been compromised.	Check if O-ring seal on the water cap is seated properly in the water cap to prevent leaking. Check for leaks before use. If leak continues, do not use. Unplug and contact manufacturer.

CLEANING AND MAINTENANCE INSTRUCTIONS

Lack of humidity can dry out your skin and can cause irritated nasal passages, frequent colds, sore throats, and other problems. Humidifiers provide relative humidity to protect your health. To get the most benefit from the humidifier and avoid product failure, follow all maintenance instructions carefully. If the recommended care and maintenance guidelines are not followed, micro-organisms may be able to grow in the water within the humidifier.

DAILY MAINTENANCE

- Before cleaning, turn the power OFF and unplug the unit.
- Lift the tank off the humidifier.
- Carry the water tank to a sink; drain and rinse the water tank thoroughly to remove any sediment and dirt. Wipe clean and dry with a clean soft cloth or paper towel.
- Refill the water tank with cool water.

WEEKLY MAINTENANCE

- Add one cup of white vinegar to the basin for approximately 15 minutes, then scrub off any scale in the basin, especially in the transducer, with a soft brush.
- Remove the scale and white vinegar solution with a clean soft cloth.
- Refill the water tank with cool water.

MAINTENANCE PRECAUTIONS

- Make sure main body is never submerged into water
- Do not use any solvents or aggressive cleaning agents to clean the humidifier.
- Clean the inner parts with a soft cloth.
- Only soft-bristle use a brush to clean the transducer. This should be done once a week.
- Change the water in the water tank at least once a week.

STORING THE HUMIDIFIER

- Clean the humidifier as described earlier and dry thoroughly.
- Preferably store the humidifier in its original box.
- Avoid high temperatures.

CONSUMER SAFETY INFORMATION

This is an electrical appliance and requires attention when in use. If moisture forms on the walls or windows of the room, turn off the humidifier. The room already has plenty of humidity and additional moisture may cause damage. Do not block air inlet or outlet.

CORD AND PLUG INSTALLATION SAFETY INSTRUCTIONS

The length of cord used on this appliance was selected to reduce the hazards of becoming tangled in or tripping over a longer cord. If a longer cord is necessary, an approved extension cord may be used. The electrical rating of the extension cord must be equal to or greater than the rating of the humidifier. Care must be taken to arrange the extension cord so that it will not drape over the countertop or table top where it can be pulled on by children or accidentally tripped over.

PRE-OPERATING INSTRUCTIONS

1. Be sure the humidifier is OFF and disconnected from the electrical outlet.
2. Place on a level surface or floor.
3. Filling the water tank
 - Remove the water tank by holding the water tank and lifting straight upward. (See figure 1)
 - Twist off the tank cap located on the bottom of the tank by turning counter clockwise and fill the water tank with cool, fresh water. **DO NOT FILL WITH WARM WATER AS THIS MAY CAUSE LEAKING.**
 - After filling the tank, replace the tank cap by firmly turning clockwise (Do not overtighten) and then replace the water tank on the base. The tank will immediately begin to filling the base. Check for leaks.

Plug the power cord into an electrical outlet.

MAIN FEATURES

- Mini space saving design
- Easily adjustable moisture levels
- 360 degree rotating mist outlet
- Automatically switches off when water tank is empty
- Transparent water tank for easy viewing
- Optional night light for easy viewing in the dark

OPERATING INSTRUCTIONS

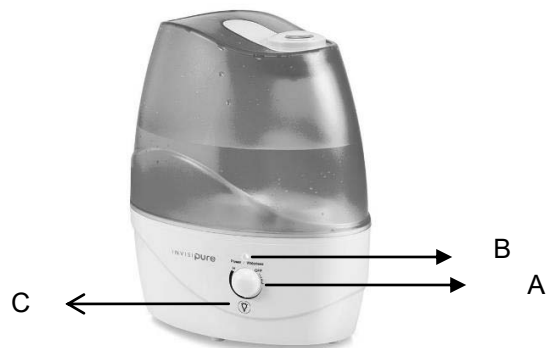

A) Power and moisture control knob

- Turn the control knob A clockwise to turn the humidifier on and increase the mist emission.
- Turn the control knob A counter-clockwise to reduce the mist emission and turn the humidifier off.

B) Indicator light for power or low water level

-Indicator light for power on: Green

-Indicator light for low water level: Red

If the indicator light becomes red, please turn off the unit, refill the water tank, place the water tank back on the base and then turn the unit back on to resume operation.

If the indicator light flashes red and green, this means the water level is low in the basin. Please turn off the unit, refill the water tank, place the water tank on and then turn the unit on to resume operation.

C) Mist outlet

- Rotating the 360 degree mist outlet, changes the direction of the mist output
- Aim the mist outlet away from walls and furniture

D) Night light control

- The night light can only be controlled when the unit is on.
- Press once to turn the night light on and once to turn night light off

ATTENTION!

If condensation forms on your windows or walls, please turn the humidifier off.

DESCRIPTION OF THE HUMIDIFIER

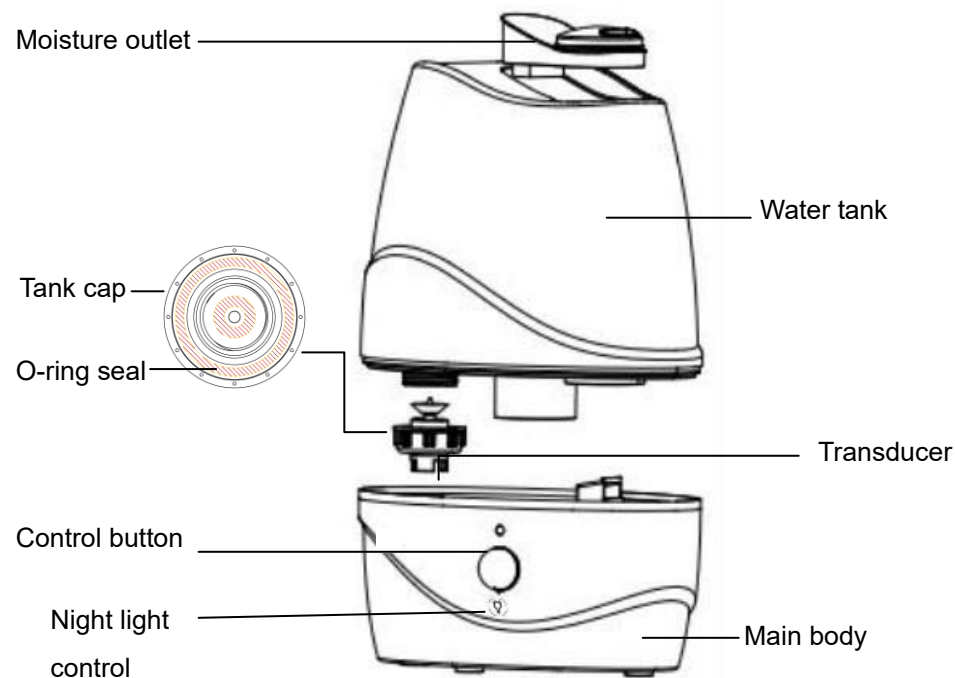

TECHNICAL DATA

- Product name: InvisiPure Cool Mist Ultrasonic Humidifier
- Input voltage: AC: 100 V-240 V, 50~60 Hz DC: 24 V
- Moisture capacity: 6.75 oz/h / 200ml/h
- Water tank volume: 85 oz / 2.5 L
- Rated power: 24 W
- Dimensions (LxWxH): 8.9" x 5.6" x 10.3" / 226 x 141 x 262 mm
- Weight: 1.75 lbs / 0.8 kg
- Coverage Area: 270 sq ft / 25 m²